

Nursing care beds

- domiflex[®] 3
- domiflex[®] 3 plus
- domiflex[®] 3 low

.bock^{///}

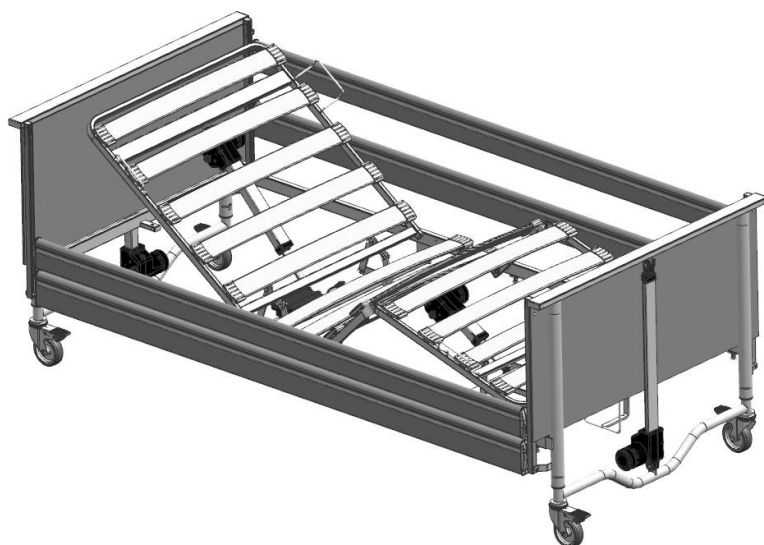

Dear Customer,

By purchasing a nursing care bed from Hermann Bock GmbH, you are receiving a long-lasting health care product with first-rate functionality at the highest level of safety.

Our electrically operated nursing care beds guarantee optimum lying comfort and allow professional care at the same time. The focus here is on the person in need of care, whose confidence must be strengthened and whose life and health are important to be protected. With this health care product, we have created the foundation to meet these requirements.

For your part, we ask that you fully comply with the safety and operating instructions in this manual, and with all maintenance requirements, in order to prevent any equipment malfunction or risk of injury.

A handwritten signature in blue ink, appearing to read 'Klaus Bock', with a stylized flourish at the end.

Klaus Bock

Table of contents

1	Preface and general notes	6
1.1	Intended use.....	6
1.2	Contraindications.....	7
1.3	Definition of person groups	7
1.4	Obligations as operator	8
1.5	Safety instructions	9
1.6	Service life.....	12
1.7	Warranty.....	12
1.8	Market reference	12
1.9	Requirements for the installation site	13
1.10	Type plate	15
2	General description of the functions	17
2.1	Operation of the electrical adjustment functions.....	18
2.2	Operation of the continuous side rail.....	19
2.3	Other side rail variants.....	20
3	Electrical components	21
3.1	Drive units	21
3.2	Drive systems.....	21
3.3	Dual drive system - domiflex® 3.....	22
3.4	Drive system with separate linear drives - domiflex® 3 plus	22
3.5	External SMPS (switch-mode power supply)	22
3.6	Operating state display of the external switch-mode power supply unit	23
3.7	Hand control	24
4	Assembly, disassembly, disposal	25
4.1	Technical specifications	25
4.2	Model series domiflex® 3.....	27
4.3	Assembly and installation videos	27
4.4	Assembly and installation of domiflex® 3 and domiflex® 3 plus.....	28
4.5	domiflex® 3 - Stowing the transport system.....	34
4.6	domiflex® 3 - transport system.....	34
4.7	Taking out of service.....	37
4.8	Disassembly	38
4.9	Relocating the bed	38
4.10	Transport, storage and operating conditions.....	38
4.11	Disposal	38
4.12	Troubleshooting	39
5	Product accessories	41
5.1	Bed extension.....	41
5.2	Lifting pole with triangle handle.....	43
5.3	Side rail bumpers.....	44
5.4	Side rail height extender	44
5.5	Grab rail with crossbeam holder	45

5.6	Reinforcement bars for 185 kg patient weight	45
5.7	Reinforcement brackets.....	47
5.8	Hand control Trendelenburg	48
5.9	Requirements for Mattresses	49
6	Cleaning, care and disinfection.....	50
6.1	Cleaning and care	50
6.2	Disinfection	51
6.3	Avoiding hazards.....	51
6.4	Machine cleaning	52
7	Guidelines and manufacturer declaration	54
7.1	EU declaration of conformity.....	55
8	Safe use in a domestic environment.....	56
9	Regular inspections with service	57

1 Preface and general notes

The different nursing care bed systems from Hermann Bock GmbH meet special requirements for use in nursing and therapy facilities as well as for care at home. At the same time, reliable functionality and durability distinguish each individual care bed as being of particularly high quality. With proper operation and inspection, the care bed remains correspondingly maintenance-free. Each Hermann Bock care bed only leaves production after passing a quality test in the final inspection. The care beds are manufactured and tested in accordance with the currently applicable standards for medically used care beds.

The nursing care beds are compliant with the EN 60601-2-52 standard. The electrical components are compliant with the EN 60601-1 safety standard for medical devices. Nursing care beds are medical devices and are categorised as Class 1.

The standard divides nursing care beds into five different application environments:

1. Intensive care in a hospital, intensive-care bed
2. Acute care in a hospital or other medical facility, patient bed in a hospital
3. Long-term care in a medical environment, stationary nursing care bed
4. Care at home, pure so-called "Home-Care bed"
5. Ambulant care

1.1 Intended use

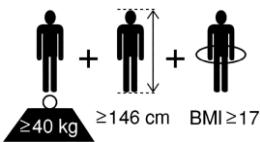

The nursing care bed is suitable for patients 146 cm or taller in height and a minimum weight of 40 kg. The patient's weight may not exceed the maximum body mass indicated on the nameplate. The patient's body mass index (BMI) must be 17 or greater.

The nursing care bed may be used in nursing or retirement homes and rehabilitation facilities. Its purpose is to alleviate a patient's disability and to make it easier for nursing staff to provide care. In addition, the nursing care bed was designed as a convenient solution for patients requiring care at home and for people with disabilities. The nursing care beds described below are thus intended for application environments 3 to 5 above. Any other use is incompatible with the intended use and excluded from any claims of liability.

The nursing care bed is delivered without the Trendelenburg function as standard. The Trendelenburg function is available as an option for application environments 3 and 5.

The Trendelenburg function may only be used by qualified medical personnel. Nursing care beds intended for application environment 4 are equipped with a hand control that cannot control the Trendelenburg function.

The nursing care bed is not suitable for use in hospitals. It is also not designed for transporting patients. The nursing beds are only mobile within the patient's room - also during patient positioning - for example for cleaning or for better access to the patient.

The nursing care bed is suitable for re-use. Please follow all guidelines in these assembly and operation manual for cleaning, care and disinfection of the nursing care bed prior to re-use. Please pay particular attention to all information about inspecting the bed.

1.2 Contraindications

This bed is intended only for patients/residents who meet the following minimum body size and weight requirements:

- Height of 146 cm or taller
- Weight of 40 kg or higher
- Body mass index of 17 or higher

1.3 Definition of person groups

Operator

Operators (e.g. a medical supply stores, specialist dealers, institutions or funding organizations) include any physical or legal person that uses the nursing care beds or on whose behalf the nursing care beds are used. The operator is always responsible for proper use of the product.

User

Users are persons who are authorised on the basis of their education, experience or product training to operate or perform work on the nursing care bed. The user is able to identify and/or prevent possible hazards and to assess the patient's state of health.

Patient/Resident/Layman

The person in need of care, infirm person, or person with a disability who is lying in the nursing care bed. An instruction of the resident in the functions of the bed that are important for him by the operator, or the nursing staff is necessary for each new occupancy. An introduction to how the resident has to behave in the event of unfavourable conditions of use. See the chapter Safe Use in a Home Environment.

Qualified personnel

Qualified personnel are employees of the operator who are authorised on the basis of their education or training to deliver, assemble, disassemble and transport the nursing care bed. In addition to operation, assembly and disassembly of the nursing care bed, these persons have been instructed in the guidelines for cleaning and disinfecting the nursing care bed.

1.4 Obligations as operator

The applicable national regulations on the obligations of the operator must be taken into account.

Advise the nursing staff of the storage location of these instructions for use in accordance with the Medical Devices Regulation. All the applicable national regulations must be taken into account. Instruct the nursing staff in the safe operation of the nursing bed by means of this operation manual before the initial start-up.

Draw the attention of the nursing staff to possible hazards in case of improper use of the nursing bed. This applies in particular to the handling of the electrical drives and side rails.

According to the Medical Devices Operator Ordinance (MPBetreibV), operators must record their stock of electrically adjustable hospital and care beds (active medical devices) and keep an inventory.

1.5 Safety instructions

This operation manual contains safety instructions. All persons working with the nursing care beds must be familiar with the contents of this manual. Improper operation can lead to hazards.

Explanation of safety instructions



DANGER

Signal word used to indicate an imminently hazardous situation which, if not avoided, will result in death or serious injury



WARNING

Signal word used to indicate a potentially hazardous situation which, if not avoided, could result in death or serious injury



CAUTION

Signal word used to indicate a potentially hazardous situation which, if not avoided, could result in minor or moderate injury



ATTENTION

This symbol indicates important information which, if not observed, could result in damage to property.

General safety instructions

The correct use of all moving parts is just as important for avoiding danger to the person in need of care as it is for the safety of relatives and/or care staff. This requires the correct assembly and operation of the nursing care bed. The individual physical constitution of the person in need of care and the type and extent of the disability must also be taken into account when operating the nursing care bed.



WARNING

Risk of injury due to incorrect operation

The nursing care bed may only be operated by trained care staff or relatives or in the presence of trained persons.



WARNING

Risk of injury due to unintentional motorised adjustments

Before the user, e.g. the nursing staff or caring relatives, leaves the room, they must

- move the lying surface to its lowest position,
- activate the locking function on the hand control by turning the key in the locking lock on the back,
- remove the key, and
- check that the hand control functions are actually locked.



WARNING

Danger of injury due to jamming

- Only use accessories approved by Hermann Bock GmbH for your nursing care bed! This applies in particular to side rails.
- Before adjusting the lying surface, take particular care to ensure that there are no limbs between the side rails! Even if the side rails themselves are adjusted, ensure that the patient is lying in the correct position.
- Before making an electrical adjustment, always check whether there are any limbs in the adjustment area between the lower frame and the head or foot section or even people or pets between the floor and the raised lying surface! There is a particularly high risk of crushing in these areas.

These actions are especially important to follow

- if the patient cannot safely operate the hand control functions themselves due to certain disabilities,
- if the patient or nursing staff could be put at risk by unintended adjustments,
- if the side rails are raised and there is a risk of pinching or crushing,
- if unsupervised children are present in the room with the nursing care bed.



WARNING

Risk of injury

In the event of a malfunction or functional failure, persons in the nursing care bed must be removed from the bed immediately.

Service and maintenance must not be carried out while the nursing care bed is being used by a patient.



WARNING

Risk of injury due to electric shock

The beds do not have any special connection options for potential equalization.

Do not use medical electrical devices that are connected to the patient intravascularly or intracardially at the same time as this nursing care bed!

The operator of the medical devices is responsible for ensuring that the combination of devices fulfils the requirements for electrical safety (EN 60601-1).



ATTENTION

Risk of damage during adjustment

Before adjusting the lying surface, make sure that there are no objects in the immediate vicinity or underneath the care bed.



ATTENTION

Risk of damage to the hand control

Always ensure that the hand control is securely attached to the nursing care bed with the suspension hook when not in use and cannot fall down.

**ATTENTION****Risk of damage due to overload**

The authorised patient weight depends on the total weight of the accessories (mattresses or additional medical electrical equipment) attached at the same time. Please refer to the type plate on the frame of the lying surface for the safe working load.

**ATTENTION****Risk of damage due to improper use**

The nursing care bed may only be used for the care and positioning of persons. The adjustment options at the head and foot end are exclusively for changing the positioning of the respective body area of a patient. The nursing care bed may only be used for its intended purpose and must not be used for purposes other than those for which it is intended or used improperly.

The back and leg sections must not be loaded with the full body weight when the bed is raised (e.g. by sitting on the back section).

To take the nursing care bed out of operation and safely switch it off, pull the mains plug out of the socket.

1.6 Service life

This nursing care bed was designed, engineered and manufactured to operate safely for a long period of time. When used and operated correctly, this nursing care bed has an expected service life of 10 years. The service life depends on operating conditions and frequencies.

1.7 Warranty

For your warranty conditions for this nursing care bed, please consult your sales contact person. Any unauthorised technical modification to the product shall immediately void all warranty claims.

1.8 Market reference

This product is not approved for the North American market, particularly not for the United States of America (USA). Distribution and use of this nursing care bed in these markets, including via third parties, is prohibited by the manufacturer.

1.9 Requirements for the installation site



WARNING

Risk of injury, fire and electric shock

Ensure that the nursing care bed is located at an appropriate distance from curtains, blinds, heaters and power sockets with which the nursing care bed may collide or come into contact, particularly during adjustments.



WARNING

Damage due to mutual interference between electrical devices

Avoid using the nursing care bed together with other electrical (medical) equipment.

If the use of additional equipment cannot be avoided, the bed and all additional equipment must be checked for correct operation by trained specialist personnel throughout the entire operation.

Apart from the necessary adjustment, the functions of the bed must be deactivated via the integrated locking function of the hand control for the duration of operation of the additional equipment.



WARNING

Damage due to interference from portable communication devices

Using the nursing care bed directly next to portable communication devices can lead to incorrect operation.

Portable communication devices, including their accessories, such as antenna cables and external antennas, should be kept at least 30 cm away from the electrical components and lines of the nursing care bed.



WARNING

Risk of injury

Ensure that the nursing care bed is positioned in such a way that the power supply unit is easily accessible so that the nursing care bed can be disconnected from the power supply!



CAUTION

Danger of swallowing small parts within reach of the patient

Make sure that medication, cords, rubber bands, small toys or other small objects such as money cannot be reached from any position in the nursing care bed!



ATTENTION

Risk of damage to the nursing care bed due to objects in the immediate vicinity or unsuitable positioning

Objects in the vicinity of the nursing care bed, e.g. chests of drawers, heating units, etc. can damage the bed during adjustment. The power supply unit can also be damaged if it collides with the nursing care bed during height adjustment.

Observe sufficient safety distances when setting up the bed!



ATTENTION

Risk of damage to the floor due to unsuitable covering

To avoid floor indentations, make sure that the flooring is suitable for the expected weight and for the operation of rolls on the floor.

Hermann Bock GmbH is not liable for damage caused by everyday use on the floor.



ATTENTION

Possibility of mutual electromagnetic interference

If electrical devices are used at the same time, small electromagnetic interactions between these electrical devices may occur, particularly in the immediate vicinity of the operational nursing care bed, e.g. noise on the radio. In such rare cases, increase the distance between devices, do not use the same socket or switch off the interfering or disturbed device temporarily.

1.10 Type plate

Each nursing care bed is labelled with an individual and a general type plate.

Individual and general type plate

REF XXXX XXXXXXXXXX	SN XXXXXXXX XXXXXXXXXX	UDI (01)04063588XXXXXX (21)XXXXXXXXXX	 =40 kg ≥146 cm BMI ≥17		
= xxx kg	Rev. XX	mmJJJJ-MM			CH REP Sodimed S. A. Chemin de Praz-Devant 12 1032 Romanel-sur-Lausanne
= xxx kg	100 - 240 V- 2,0 - 1,2 A INT 10% (2 min ON/16 min Off)	50/60 Hz IPX4			UK RP Carebase - Unit 6-7 Moxon Court Thurston Road - Northallerton - DL6 2NG 890.02355 - Rev. 03 Made in Germany





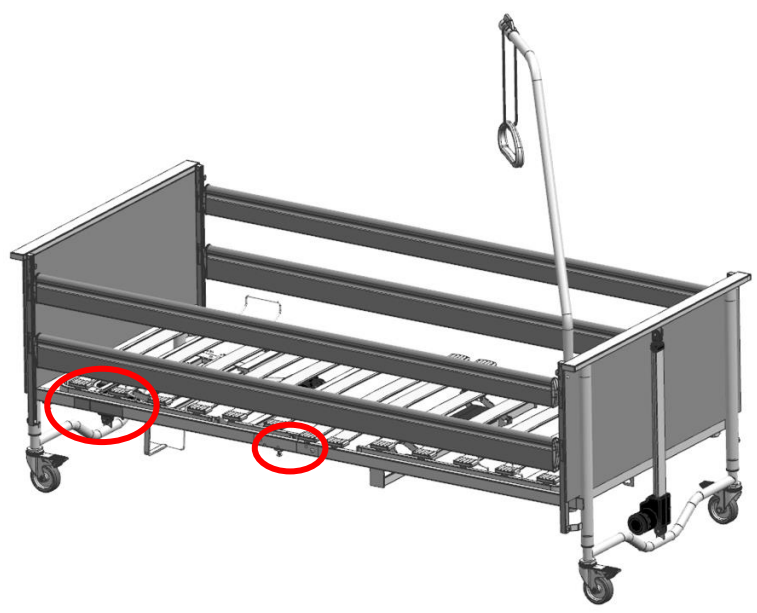















Positioning of the type plate:

The type plates are located on the frame of the lying surface, on the foot side:



For models in the domiflex® 3 range, the maximum patient weight and the safe working load are indicated on a separate label in the middle of the lying surface. By installing reinforcement elements (see 5.6 and 5.7), the original labeling is covered by the indication of the increased maximum patient weight or the increased safe working load.

Explanation of symbols

	Article number		Maximum patient weight
	Serial number		Safe working load
	Unique Device Identification acc. to MDR	max. 	Maximum total mass of the nursing care bed including the safe working load
	Production date (Year - Month)		Medical device
	Conformity marking according to the Medical Device Regulation		Physical description of an adult
	Refer to manual		Follow guidelines for mattress size and thickness
	Product is subject to separate waste disposal requirements in the European Union. Product may not be disposed of in household waste.		Manufacturer's address
	Type BF medical applied part		UK Conformity marking
	Use only in dry areas		UK Responsible Person
	Protection class II (double insulation, protective insulation)		Swiss Representative
IPX4 / IPX6	Protection of electrical equipment against splash water		

2 General description of the functions

Construction and function

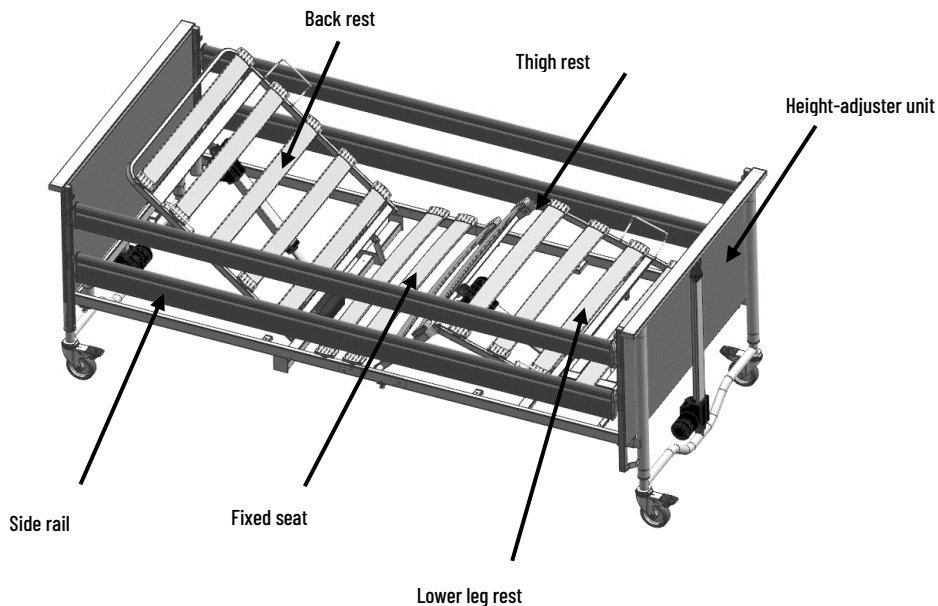

Four-section lying surface











The lying surface comes standard with a comfort slatted frame (or can alternatively be fitted with aluminium slats) and is divided into four sections: back rest, fixed seat, thigh rest and lower leg rest.

Chassis

The height adjustment of the nursing care beds is done by two height-adjuster units.

2.1 Operation of the electrical adjustment functions

The functions of the nursing care bed can be controlled at the touch of a finger on the control buttons. The individual control buttons are labelled with corresponding symbols. The actuators run for as long as a corresponding button is held down.

- | | |
|--|---|
|  | Back rest upwards |
|  | Back rest downwards |
|  | Lower leg rest upwards |
|  | Lower leg rest downwards |
|  | Lying surface upwards |
|  | Lying surface downwards |
|  | Foot-down position (anti-Trendelenburg)* |
|  | Head-down position (Trendelenburg)* |
|  | Comfort sitting position* (upward only**) |
|  | Release of lowering function* |
|  | Light on/off* |

* Availability depends on model

** This button will only raise the bed into the sitting position. The affected sections must each be lowered individually.

Domiflex® 3 low - Low position

The domiflex® 3 low version has a comfort exit position at a lying surface height of 35 cm. When the bed is lowered, it stops automatically in this position. If the bed is to be moved to its lowest position, the low function release button  must be pressed, once the comfort exit position has been reached.



WARNING

Risk of injury due to crushing when moving to low position

Before activating the low function release button, make sure that there are no body parts or objects under the bed.

2.2 Operation of the continuous side rail

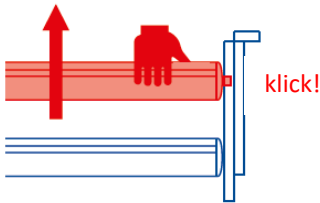

When needed, the integrated side rails must be pulled up until they click into position. When using mattresses of different thicknesses, a minimum distance of 22 cm must be maintained between the top edge of the side rail and the mattress without compression; otherwise, a third top-mounted rail should be used.

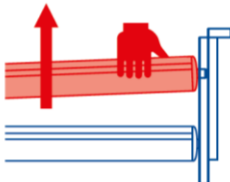

Step 1: Grip side rail and lift slightly.

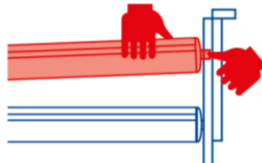

Step 2: Press release button.

Note: Be sure to lift the side rail slightly and then press the release button!

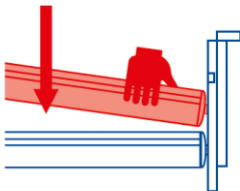

Step 3: Downward lowering.

Note: Both sides must be lowered!

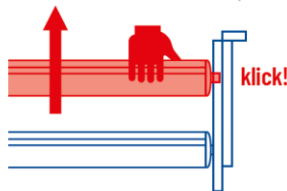

Bring to the top position as fall protection:

Pull the side rails up until it clicks audibly into place at the end

The release button for adjusting the continuous side rails is located just above the upper side rail in the sliding track.

To lower the side rails, hold the provided gripping groove of the upper side rail, lift the side rail slightly, and press the release button on either the headboard or foot-board. The side rail is then released on that side and can be easily lowered to the end of the track. The side rail is now in a diagonal position. To lower the other side, perform these steps again at the opposite end

of the bed. The side rail is now in its lowered position.



ATTENTION

Risk of damage to the release mechanism

Make sure to lift the side rail slightly before pressing the release button!

The primary purpose of the side rails is to protect the patient from falling out. For extremely emaciated patients, the side rails no longer offer adequate fall protection, and additional protective measures must be taken, e.g. by placing additional fitted side-rail bumpers (product accessory) in the bed.

**WARNING****Risk of injury due to crushing and trapping**

- Only use original Bock side rails!
- Only use technically flawless and undamaged side rails with the correct gap dimensions!
- Ensure that the side rails engage securely!
- Only use the side rails as described in the operating instructions!
- Before attaching the side rails and with each new use of the nursing care bed, check all mechanical parts on the nursing care bed and the side rails for possible damages.

**WARNING****Risk of injury due to crushing during adjustment**

Be aware of the increased risk of entrapment when adjusting the backrest and thigh rest while the side rails are engaged!

2.3 Other side rail variants

The domiflex® 3 can be fitted with the SR2 side rail. The SR2 side rail comes with its own assembly and operating manual.

When using different mattress thicknesses, the minimum height, measured from the upper edge of the side rails above the mattress, must not be below 22 cm, without compression.

Therefore, the following measurements must be observed for safe use of the side rails:

- Height above the mattress: $\geq 220\text{mm}$
- Gap dimensions between bars and to the lying surface: $<120\text{mm}$
- Gap dimensions between side rail and end panel: $<60\text{mm}$ or $>318\text{mm}$

3 Electrical components

3.1 Drive units

Depending on the model, the drive unit consists either of a main motor (dual drive, domiflex® 3), or two individual single drives for motorised adjustment of head rest and leg rest positions. The bed is adjusted in height by means of a linear drive in each end panel actuator. The motors and the hand control are connected to the internal control box. The power supply unit converts the input voltage to a safety extra-low voltage of max. 35V DC. This safety extra-low voltage is used to operate the motors and the hand control. Cables are double-insulated, and the power supply unit has a primary fuse.

3.2 Drive systems

The domiflex® 3 is equipped with Limoss drives (drive system with external switch-mode power supply) for individual adjustment of the back rest and foot rest and height adjustment. A distinction is made between the following versions:

domiflex® 3: Dual drive system – 1 main motor
(see chapter 3.3)

domiflex® 3 plus: System with 2 separate linear drives
(see chapter 3.4)

The internal emergency lowering system is powered by 9 V block batteries. The safety features correspond to protection class II and the moisture protection corresponds to protection class IPX4 or IPX6 in case of the washable version.



9V block battery for emergency lowering (dual drive)



WARNING

Danger due to failure of the emergency lowering system

The 9-volt batteries of the control unit must be checked for functionality once a year and replaced if necessary. In addition, regular visual inspections must be carried out.

3.3 Dual drive system - domiflex® 3

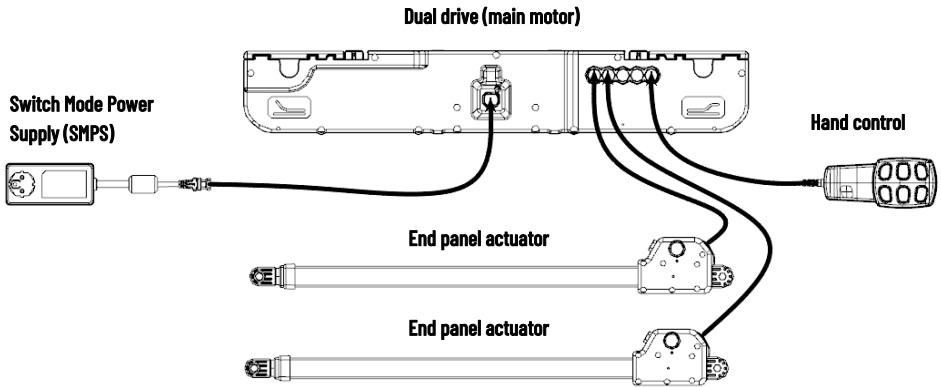

3.4 Drive system with separate linear drives - domiflex® 3 plus

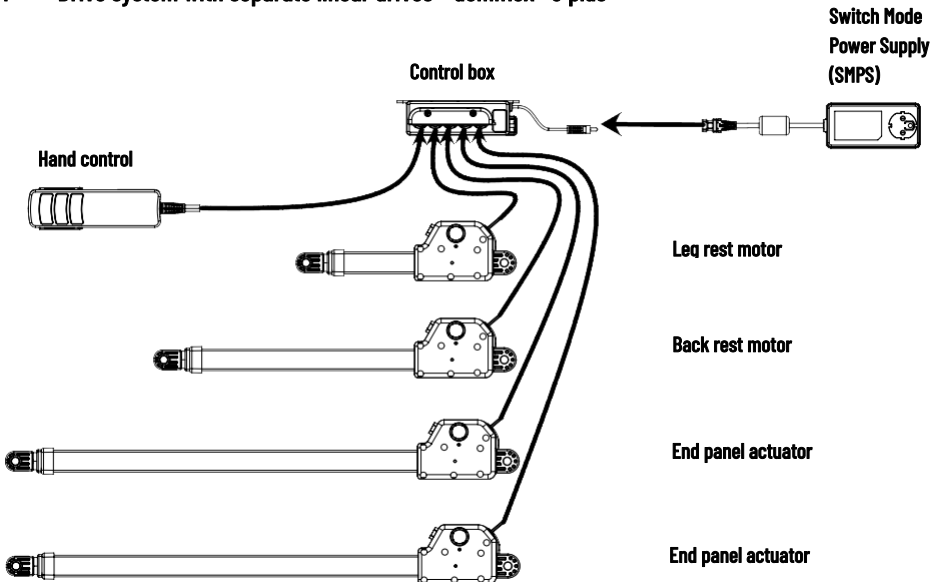

3.5 External SMPS (switch-mode power supply)

The drive system includes a primary fuse in the power supply unit and an emergency lowering mechanism. The SMPS (switch-mode power supply) is an electronic transformer that warms up only minimally under load and has an integrated electronic power monitoring unit. The resulting system provides constant voltage up to the load limit (no loss of speed) and strong protection against overloading. The external transformer provides safety right from the wall socket, where

it transforms the mains voltage directly into the safety extra-low voltage used to operate the nursing care bed. It is connected to the mains power supply cable by means of a plug coupling, so that it can be replaced separately in case of a defect.

The power supply unit complies with European guidelines for household electrical devices, so it also maintains low energy consumption of no more than 0.5 watts in standby mode and can be used internationally with input voltages from 100 V to 240 V. No alternating electromagnetic fields can be detected at the SMPS, and such fields are even lower during operation (due to the very low direct current) than when disconnected from mains power.

The maximum switch-on duration is indicated on the nursing care bed (type plate): 10% duty cycle (2 min. ON / 18 min. OFF) means that each electrical adjustment may be operated for a maximum of 2 minutes in 20 minutes (overheating protection).

If the maximum adjustment time of two minutes is exceeded, for example due to prolonged operation of the hand control, and the motors overheat, the thermal fuse immediately switches off the power supply to the care bed completely. After a cooling time of approx. one hour, the power supply is automatically restored.



WARNING

Danger due to not being ready for operation

If the maximum adjustment time of two minutes is exceeded, for example by continuously pressing a hand control button, and the motors overheat, the thermal fuse immediately switches off the power supply to the nursing care bed completely. After a cooling time of approx. one hour, the power supply is automatically restored.

Do not exceed the maximum switch-on time of 2 minutes! A subsequent break of at least 18 minutes must be observed.

3.6 Operating state display of the external switch-mode power supply unit

The switch-mode power supply SMPS has an LED that can indicate the following operating states:

- LED On: Ready for operation
- LED Off: Discharged, not connected
- LED flashing: Error, thermal overload, or short circuit.

After disconnecting the mains plug or the connection to the motor, the LED "glows" and then turns off.

3.7 Hand control

The hand control includes an integrated locking mechanism that allows nursing staff to fully or partially lock hand control functions with a key.

The hand control can be suspended on the nursing care bed using the rear-mounted suspension hook, especially during cleaning or when providing patient care. The hand control can thus be clipped to any position on the nursing care bed, in order to avoid any possible disturbing position.

Hand control – Locking functions

The hand control includes an integrated locking device that can be activated and deactivated with the corresponding key. To lock out all electrical functions, place the key into the lock on the back of the hand control and turn the key to turn the locking function on or off.

Locking device 1 (Standard)

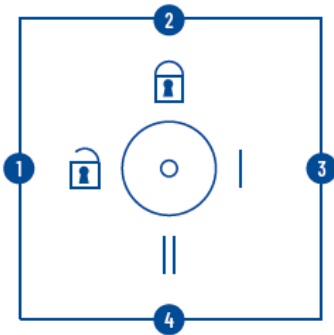

Locking device

1, 3, 4:
All functions
executable

2:
All hand control func-
tions locked

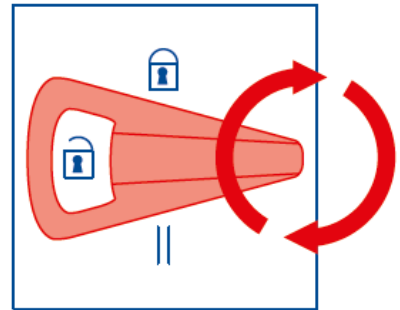

Key for the locking device

Locking device 2 (Option with Trendelenburg function)

	1	Only Trendelenburg function is locked
	2	All hand control functions locked
	3 + 4	All functions available (incl. Trendelenburg function, if applicable)

4 Assembly, disassembly, disposal

4.1 Technical specifications

Technical data	domiflex® 3 domiflex® 3 185	domiflex® 3 low domiflex® 3 low 185
Lying surface dimensions: cm	Widths: 80, 90, 100, 105, 110 Lengths: 180 (200), 200 (220)	
External dimensions: cm (W x H x L)	Height: 81 Width: Lying surface + 11 Length: Lying surface +11	Height: 78 Width: Lying surface + 11 Length: Lying surface + 11
Safe working load: kg		
standard	190	190
reinforced	220	220
Max. patient weight: kg		
standard	155	155
reinforced	185	185
Height adjustment range: cm	35 - 80	24 - 69
Back rest length: cm	66	66
Lifter floor clearance: cm	> 15	> 15*
Noise level: dB(A)	< 65	< 65
Adjustment angle		
Back rest	70°	70°
Thigh rest	42°	42°
Lower leg rest	16°	16°
Trendelenburg position	12.6°	12.6°
Weights (90 x 200)		
Total incl. wooden side rails: kg	71.4	73.0
Lying surface, head: kg	13.8	13.8
Lying surface, foot: kg	11.6	11.6
End panel: kg	15.3	15.8
Wooden side rails (pair): kg	11.4	11.4
Electrical specifications		
Input voltage: V	100-240	100-240
Frequency: Hz	50/60	50/60
Max. power consumption: A	2.1-0.9	2.1-0.9

* Refers to the entry position (stop before lowest setting)

All information given in brackets refers to the domiflex® 3 nursing care bed with the bed extension installed.

Technical data	domiflex® 3 plus domiflex® 3 plus 185	domiflex® 3 plus low domiflex® 3 plus low 185
Lying surface dimensions: cm	Widths: 75, 80, 90, 100, 105, 110 Lengths: 175 (200), 180 (200), 200 (220)	
External dimensions: cm (W x H x L)	Height: 81 Width: Lying surface + 11 Length: Lying surface + 11	Height: 78 Width: Lying surface + 11 Length: Lying surface + 11
Safe working load: kg standard reinforced	190 220	190 220
Max. patient weight: kg standard reinforced	155 185	155 185
Height adjustment range: cm	35 - 80	24 - 69
Back rest length: cm	77.5	77.5
Lifter floor clearance: cm	> 15	> 15*
Noise level: dB(A)	< 65	< 65
Adjustment angle		
Back rest	70°	70°
Thigh rest	42°	42°
Lower leg rest	16°	16°
Trendelenburg position	12.6°	12.6°
Weights (90 x 200)		
Total incl. wooden side rails: kg	76.8	78
Lying surface, head: kg	20.4	20.4
Lying surface, foot: kg	14.6	14.6
End panel: kg	15.3	15.8
Wooden side rails (pair): kg	11.4	11.4
Electrical specifications		
Input voltage: V	100-240	100-240
Frequency: Hz	50/60	50/60
Max. power consumption: A	2.1-0.9	2.1-0.9

*Bezieht sich auf die Einstiegsposition (Stopp vor Niedrigfahrt)

All information given in brackets refers to the domiflex® 3 nursing care bed with the bed extension installed.

All parts and data are subject to constant development and may therefore deviate from the listed data. The technical data of variants may deviate.

4.2 Model series domiflex® 3

The model series domiflex® 3, consisting of the models domiflex® 3, domiflex® 3 plus und domiflex® 3 low was specially designed for the requirements of daily continuous use in care at home. The above-mentioned models offer a high level of lying comfort to frail people, sick people in need of care and people with disabilities, while at the same time supporting optimal care through their easy operation.





4.3 Assembly and installation videos

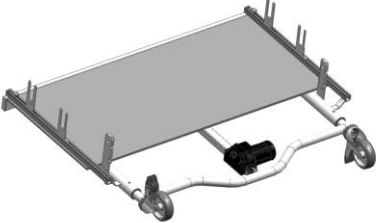
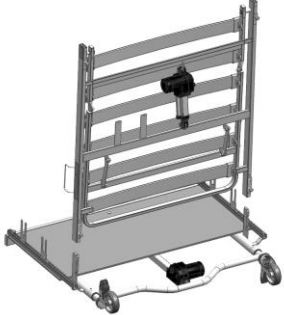
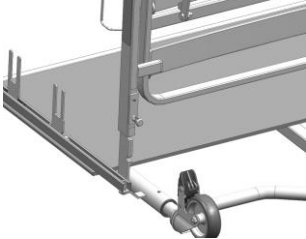
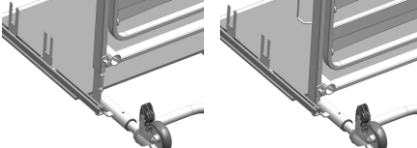

- Installation video domiflex® 3
- Installation video domiflex® 3 plus
- Installation video side rails
- Installation video bed extension
- Installation video reinforcement bars
- Video of the transport system

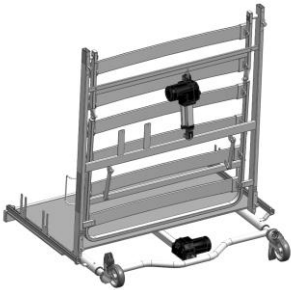

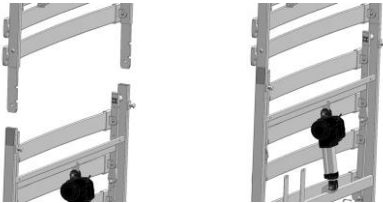
4.4 Assembly and installation of domiflex® 3 and domiflex® 3 plus

<p>Lay the end panel on the ground as shown in the figure at right. Before starting assembly, fully remove all packaging materials (incl. cable ties).</p>	
<p>Locate the foot section of the lying surface, which has no mounting bracket for the lifting pole. The tension bolts should be brought into the locking position before insertion, in order to be able to push in the lying surface completely.</p>	
<p>Connect the lying surface to the end panel by placing the lying surface on the mounting brackets. By placing the lying surface in a slightly diagonal position, it is easier to find the connectors and the assembly is more back-friendly.</p>	
<p>Make sure that the tool-free connection is pushed up to the second retaining point. Then return the tension bolt to the engaged position.</p>	

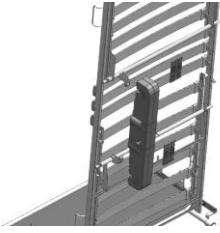
<p>Check that the lying surface is correctly connected to the end panel. The tension bolt must be clicked into place.</p>	
<p>Take the head section of the lying surface.</p>	
<p>Put the head section of the lying surface onto the foot section of the lying surface, the tool-free connection must click into place. By placing the lying surface slightly diagonally, it is easier to find the connection points and the assembly is more back-friendly.</p>	
<p>You can now connect the connections for the footrest motor and the end panel actuators to the control box according to the marking (symbol image, color coding, see chapter 3.4). The hand control and the backrest motor are already connected.</p>	

The following steps refer only to the domiflex® 3 with main motor (dual drive)	
<p>To assemble the main motor, pick up the motor and the two cover plates.</p>	
<p>Press the motor onto the motor cams. The symbols and the connection cables must face towards the inside of the bed.</p>	
<p>Slide the cover plates sideways into the locking device of the main motor.</p>	
<p>The assembly of the main motor (dual drive) is now completed. The individual drives are permanently mounted and only need to be connected during assembly. For the connection of the motor systems, see chapters 3.3 and 3.4, respectively.</p>	

Take the second end panel.



Push the end panel into the head section of the lying surface up to the first click. This is the installation and removal position for the side rails.

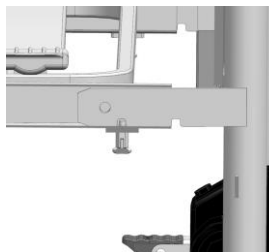

Assemble the side rails. They can be inserted in a diagonal position. Pay attention to the marking "top" and "bottom" on the plugs (end caps). This indicates whether it is the upper or lower rail. The lower rail is higher.



Pull all side rails upwards.



Then push the end panel up to the second click position of the tool-free connector. This is the final locking position.

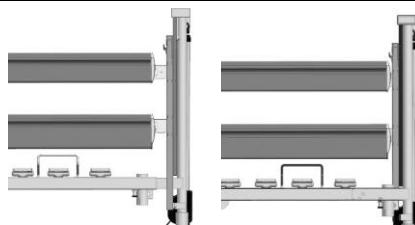

Check all tool-free connections for secure locking.

Make absolutely sure that all tension bolts are locked!

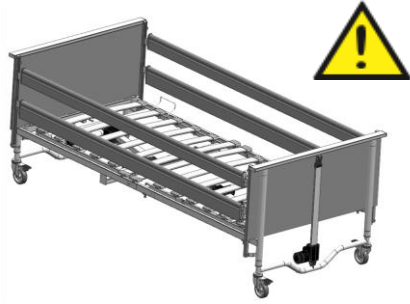



ATTENTION

Risk of damage to the electrical cables

- The cable should be laid outside the area where damage can occur.
- Contact with sharp-edged parts should be avoided.
- Cables must not be crushed.

Connect the drives according to the overview in chapters 3.3 or 3.4, depending on the version.

The cables should be laid above the intermediate tubes of the lifting elements.

Connections of the dual drive (main motor):

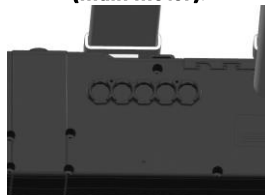

Control box for single drives:



The mains cable must be screwed to the tab on the lying surface with the strain relief device located on the cable.

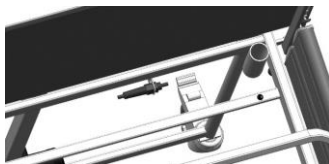

Insert the lifting pole into the mounting socket. Ensure that it is locked in place with the groove.

Carry out a complete inspection of the nursing care bed using the inspection list in Chapter 9. Your domiflex® 3 or domiflex® 3 plus nursing care bed is now ready for use.



WARNING

Risk of injury due to incorrect assembly

The nursing care bed must be inspected before each (re-)use.

Use the inspection list in chapter 9.

4.5 domiflex® 3 – Stowing the transport system

To ensure that the transport system is always ready for use, a holder has been integrated under the lying surface frame. Follow the steps below to stow the transport system.

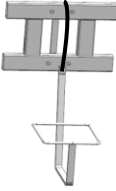
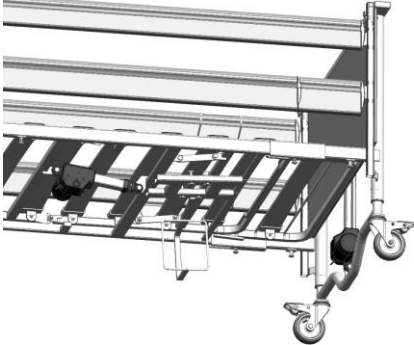
<p>Connect the transport system at the lying surface connectors in reverse and secure with the Bock securing strap.</p>	
<p>Place the transport system onto the two holders underneath the lower leg rest of the lying surface and secure it with the linchpins.</p>	

4.6 domiflex® 3 – transport system

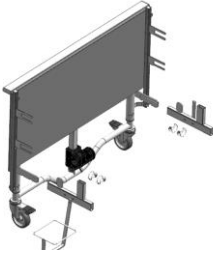
<p>The transport system consists of two connector pieces, each with a linchpin to make a connection between the end panels.</p>	
---	---

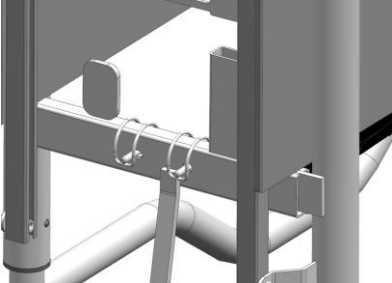
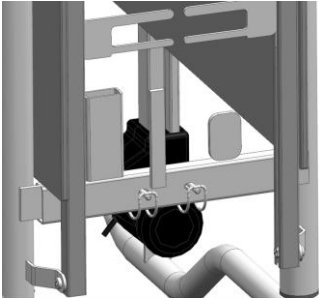
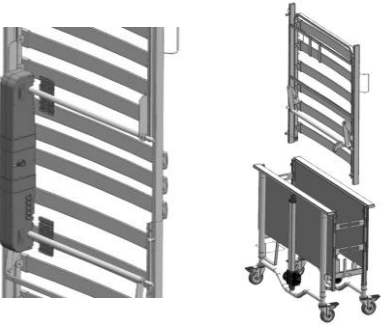
<p>Push in both end panels.</p>	
<p>Place the linchpins as shown in the figure, starting on the inside and moving to the outside, then close it.</p>	
<p>Insert the linchpin on the opposite side.</p>	
<p>Disassemble the dual drive (main motor), if present, by loosening the slides (cover plates) and then putting it aside. Next, insert the foot section of the lying surface from above. The mattress brackets should face upward and out-ward.</p>	

Then insert the head section of the lying surface from above. The mattress brackets should face upward and outward.

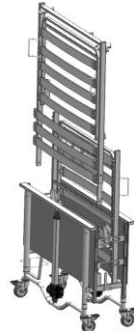

Visually compare the assembly with the figure at right.

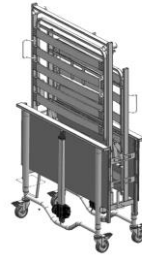

Now the side rail system now be added.

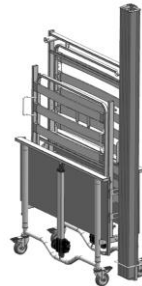

Fix the side rail to the upper side of the head-section lying surface using the Bock securing strap.

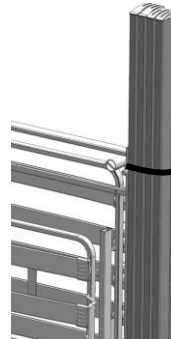

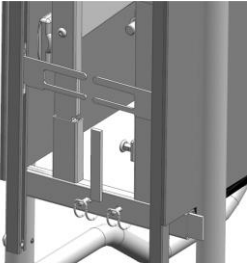
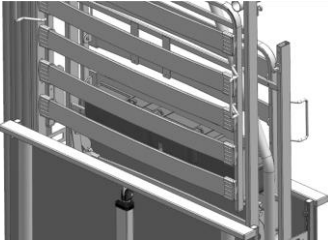
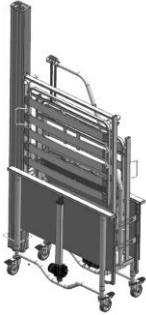
<p>Then the lifting pole can be inserted, this is placed on the existing, free flat steel. The lifting pole should face in-wards.</p> <p>Be careful not to damage the tool-free connection.</p>	
<p>For the version with dual drive (main motor): Fold out the head section of the lying surface, place the main motor incl. transformer and hand control on the round tube crossbar. Then close the head section and secure it against opening with the triangle handle.</p>	
<p>The complete transport unit is pictured at right.</p>	

4.7 Taking out of service

- Ensure that the brakes are locked.
- Move the side rails to the lowest position.
- Move the lying surface to the lowest position.
- Lock the hand control and remove the key.
- Unplug the mains plug and secure it to the frame using the suspension device to prevent the mains cable from falling and being run over.
- If the bed is not expected to be used for some time, remove the battery from the motor.

4.8 Disassembly

Before starting to disassemble the bed, unplug it from the wall socket. All the domiflex® 3 variants can be disassembled by following the assembly instructions in reverse order.

4.9 Relocating the bed

When moving the bed to a different location, please follow the safety instructions below:

- Lower the lying surface to the lowest position.
- Before moving the bed, pull out the mains plug and attach it to the frame with the hook to prevent the power cord from falling down and being run over. Ensure that the cord does not drag on the ground.
- Before reinserting the mains plug, visually inspect the power cord for any signs of mechanical damage (kinks or pinched areas, abrasions or exposed wires).

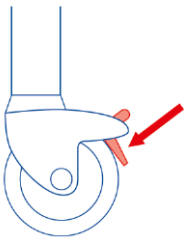

- Run the cable in such a way that it cannot be pulled, run over or be damaged by moving parts of the nursing care bed; then put the mains plug back into the socket.

- To keep the nursing care bed in a particular location, the brakes of the castors on the bed base must be locked. To do this, push the locking lever on the lower frame downwards with your foot.

4.10 Transport, storage and operating conditions

	Transport and storage	Operation
Temperature	0°C to +40°C	10°C to +40°C
Relative humidity	20% to 80%	20% to 70%
Atmospheric pressure	800hPa to 1060hPa	

4.11 Disposal

The individual plastic, metal and wooden components are recyclable, and can be disposed of for recycling in accordance with applicable laws. Note that electrically adjustable nursing care beds are considered as waste electrical equipment used for professional purposes (b2b) under EC WEEE directive 2012/19/EC. All replaced electrical and electronic components of the electrical bed adjustment system must be handled in accordance with the requirements of the applicable regulations and properly disposed of.

4.12 Troubleshooting



DANGER

Danger to life due to electric shock

Never attempt to rectify faults in the electrical equipment yourself - there is a risk to life! Either contact Hermann Bock GmbH customer service or authorized electricians who will rectify the fault in compliance with all relevant safety regulations.



DANGER

Danger to life due to electric shock

The drive components must not be opened!

Troubleshooting or the replacement of individual electrical components may only be carried out by specially authorised specialist personnel.



ATTENTION

Obligation to report serious incidents

According to the MDR, the user and/or patient is obliged to report all serious incidents that have occurred in connection with this device to the manufacturer and the competent authority of the Member State in which the user and/or patient is established.

This overview offers tips on which malfunctions you can check and easily resolve on your own, and which malfunctions should always be entrusted to qualified professionals.

Malfunction	Possible causes	Suggestion
Drive system cannot be operated via hand control	Power cable unplugged	Plug in the power cable
	No power from wall socket	Check wall socket and/or fuse box
	Hand control plug not fully in place	Check plug connection at the motor
	Hand control or drive system is defective	Inform the operator or H. Bock customer service
Motors stop working when button is pressed after running for a short time	Obstacle preventing bed from changing position	Remove obstacle
	Safe working load is exceeded	Reduce load on bed
Drive units stop after extended adjustment time	Adjustment time or safe operating weight exceeded – PolySwitch in control device's transformer has reacted to overheating	Allow the drive system to cool down sufficiently.
Height adjustment motors do not move in parallel	As the motors are not synchronised, multiple up and down movements can result in a height difference between the end panels.	Move the motors all the way up or down to restore the parallelism of the end panels.

5 Product accessories

To adapt each nursing care bed more closely to each patient's individual needs, Hermann Bock GmbH offers practical accessories to promote patient mobility. These accessories can be quickly and easily installed at their predetermined attachment points on the nursing care bed. Naturally, each additional piece of equipment meets Bock's highest standards of quality and safety.



WARNING

Risk of injury due to entrapment





- Only use accessories approved by Hermann Bock GmbH for your nursing care bed!
- When using accessories on the nursing care bed or using medically necessary equipment, e.g. infusion stands, in the immediate vicinity of the care bed, particular care must be taken to ensure that no crushing or shearing points are created for the patient when adjusting the back and leg rests.

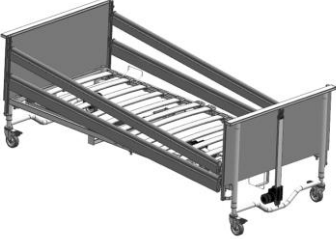

5.1 Bed extension

Part no.	400
Weight	15 kg
Scope of delivery	Kit of bed extension including 220 cm side rails

For patients taller than 180 cm, Hermann Bock GmbH recommends use of a bed extension in order to extend the lying surface to a length of 220 cm, allowing taller patients to enjoy a high level of comfort with identical functionality.



<p>Disassemble the end panel. To do this, loosen the tool-free connection and pull the end panel out of the lying surface to the first click position. Position the side rails diagonally and remove them. Then completely remove the end panel.</p>	
<p>Insert the frame extensions and lock them in place with the tool-free connection of the lying surface. Insert the foot end panel into the extension of the frame and push it in until it clicks into the first snap position. This is again the installation and removal position for the side rails (220cm).</p>	
<p>Insert the new side rails diagonally and put the foot end panel back on, as usual, following the assembly instructions for the domiflex® 3.</p>	
<p>Locate the lying surface extender and insert it at the end of the foot bar of the lying surface, as shown in the figure.</p>	

<p>Lay down the lying surface extender, so that it is levelled with the foot bar element.</p>	
<p>Once you have finished this step, your assembly of the bed extension is completed.</p>	

5.2 Lifting pole with triangle handle

Part no.	92320	
Weight	6,5 kg	
Safe working load	75 kg	
Scope of delivery	Lifting pole with mounting loop incl. triangle handle	

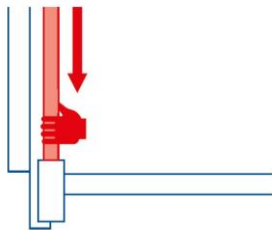

To install, insert the lifting pole into the provided socket on the head section of the bed and lock it into position. Hang the triangle handle through the mounting loop.

Be sure to use only mattresses in the thickness range recommended by Hermann Bock GmbH.

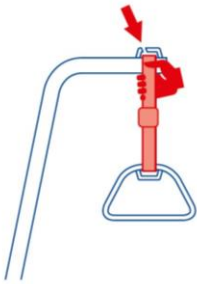

Attention: Do not swing the lifting pole outside of the lying surface!

The triangle handle (plastic parts, webbing, seams) should be checked quarterly for function and damage. We recommend to replace the triangle handle after 5 years, even if there is no visible external damage.

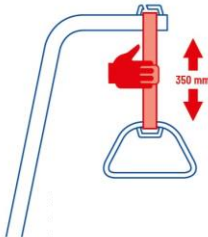

Attention: The handle must always be released during length adjustment

The grip height can be continuously adjusted through a range of about 350 mm. Depending on the mattress thickness, the triangle grip can therefore be adjusted to a height of 550 to 850 mm above the mattress surface. When using a lifting pole, the overall height of all domiflex 3[®] models is increased by 890 mm.

5.3 Side rail bumpers

Part no.	890.01581 / 890.01806 Beige / Blue	
Weight	1,4 kg	
Scope of delivery	Cover including padding	

To install, open the zip of the cover (or the hook-and-loop fastener, depending on the product version) and pull it down over the side rail. Pull the foam padding into the cover from the inside of the nursing care bed, then close the zip or hook-and-loop fastener.

5.4 Side rail height extender

Part no.	90950	
Weight	3,0 kg	
Scope of delivery	Side rail height extender, fully assembled	

Open plastic closure, place height extender on top of the side rail, position in the centre of the rail, and close. Be sure that the height extender's release button is facing outward once installed!

**WARNING****Risk of injury when using third-party side rails**

The side rail height extender is exclusively designed for use with all Bock wooden side rails.

5.5 Grab rail with crossbeam holder

Part no.	405	
Weight	3,0 kg	
Safe working load	40 kg	
Scope of delivery	Grab rail with cross-beam holder and mounting material	

<p>Screw the crossbeam holder to the lying surface frame by means of the included screws.</p>	<p>Insert the grab rail into the crossbeam holder, adjust it to the position, and tighten screws firmly.</p>

5.6 Reinforcement bars for 185 kg patient weight

Part no.	92712
Weight	9 kg
Scope of delivery	Retrofit kit reinforcement 185 kg

Take the reinforcement bars out of the packaging.

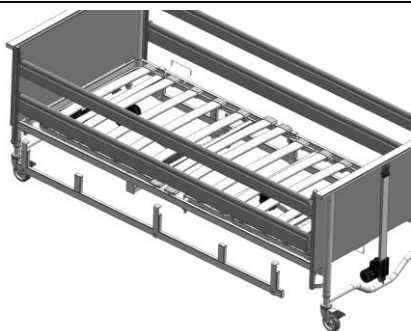

Hang the reinforcement bars onto the bed frame and mount them with the provided screws.

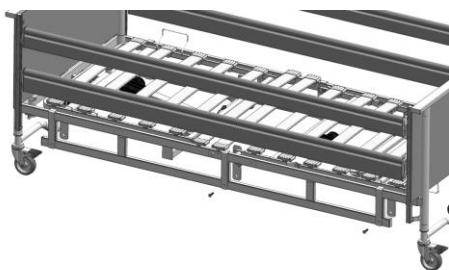

Tighten the screws connection firmly.

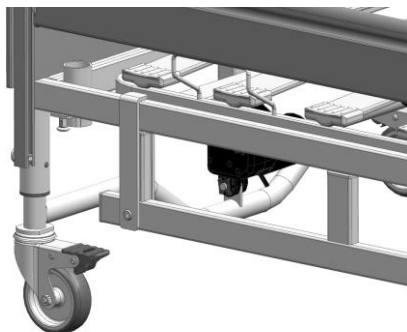

Make absolutely sure that the reinforcement bars are fitted on both sides.

Now your domiflex® 3 with reinforcement bars is ready for use.



5.7 Reinforcement brackets

Part no.	92881
Weight	2 kg
Scope of delivery	Pair of reinforcement brackets incl. mounting material

The reinforcement brackets increase the patient weight from 155 kg to 185 kg. Accordingly, the safe working load of the bed also increases from 190 kg to 220 kg.



ATTENTION

Can only be used in combination with siderails

To use these reinforcement elements, the full-length siderails must be fitted to the bed. If these siderails are not fitted, the patient weight / safe working load cannot be guaranteed.

Loosen the M8x16 threaded screw with a size 5 Allen key and remove it.

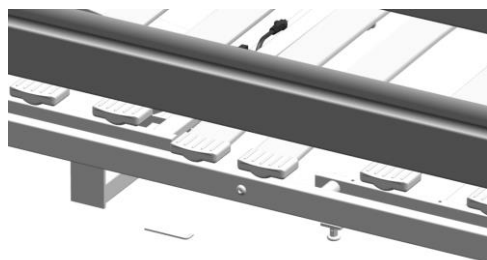

Take the reinforcement bracket for the right-hand side in this illustration and slide it over the longitudinal lying surface frame. The hole in the bracket must be aligned with the hole in the longitudinal lying surface frame.

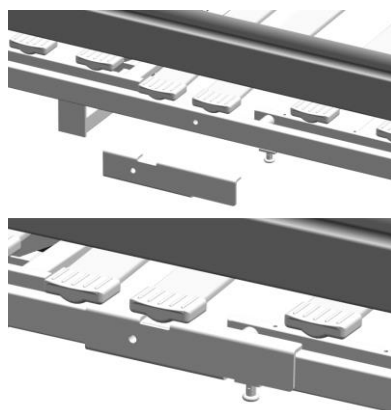

Take the provided M8x20 screw and fasten it to the longitudinal lying surface frame together with the reinforcement bracket using a size 5 Allen key. Make sure that the brackets already in the longitudinal lying surface frame do not lose their position.

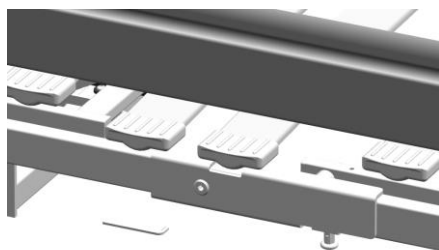

Repeat steps 1 to 3 on the second side of the bed. The installation of the reinforcement brackets is now completed.

Make absolutely sure that the reinforcement brackets are fitted on both sides.

Now your domiflex® 3 with reinforcement brackets is ready for use.

5.8 Hand control Trendelenburg

Part no.	800.00507
Weight	0,3 kg
Scope of delivery	Hand control with Trendelenburg function

To use the Trendelenburg function, you need the corresponding Trendelenburg hand control. This can replace the supplied hand control on all models.

5.9 Requirements for Mattresses

In general, nursing care beds from Hermann Bock GmbH can be equipped with any foam or latex mattress with the following specifications:

Dimensions (W x L)	According to the lying surface dimensions
Volume weight	At least 35kg/m ³
Height	Minimum 10 cm, maximum 15 cm

For thicker mattresses, an additional side rail, available as a product accessory, must be used (side rail height extender, see 5.4). The height of the side rail above the mattress must be at least 22 cm.

When using foam mattresses, we recommend cuts or notches for a closer fit to the lying surface.

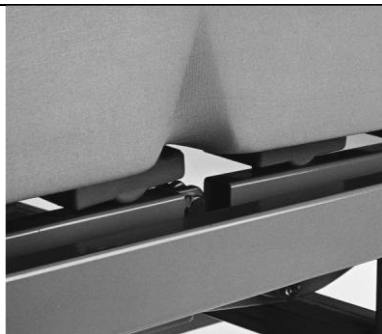

6 Cleaning, care and disinfection



WARNING

Health risk due to infectious contamination

Clean and disinfect the nursing care bed before every change of user, before repair, storage or transport!

The individual components of this nursing care bed are all made from top-quality materials. The surface of the tubular steel frame is coated with a long-lasting poly-ester powder coating. All wooden parts are sealed with low-pollutant surface sealants. All bed components can be easily cleaned and maintained in accordance with applicable hygiene requirements in the various usage environments, using wipe-down and spray disinfection techniques.

A routine cleaning of the nursing care bed within the use by the same patient is recommended every month or even if necessary. Disinfection of the nursing care bed is only necessary in case of visible contamination with infectious or potentially infectious material or in the presence of an infectious disease.

By following the care instructions in this section, the functionality and appearance of your nursing care bed can be maintained for a long time.

6.1 Cleaning and care



ATTENTION

Possibility of damage to the product due to incorrect cleaning

Never use abrasive cleaners or cleaning pads containing abrasive particles or stainless-steel care products for cleaning!

Do not use organic solvents such as halogenated/aromatic hydrocarbons and ketones as well as acidic and alkaline cleaning agents!

Under no circumstances should the care bed be sprayed with a water hose or high-pressure cleaner, as liquid could penetrate the electrical components and cause malfunctions and hazards.

Tubular steel and enamelled metal parts

To clean and care these surfaces, use a damp cloth together with standard mild household cleansers.

Wood, decorative and plastic components

All standard furniture cleansers and care products can be used with these components. For cleaning plastic elements, a damp cloth with no added cleansers is generally sufficient. When cleaning plastic surfaces, use products that are specifically intended for use on plastic.



WARNING

Risk of injury due to water penetrating electrical components

This can lead to malfunctions of the control unit and, as a result, to unintentional movements of the individual care bed elements, which harbor an increased risk of injury for the caregiver and user.

Drive system

To prevent moisture from entering the motor housing, the housing should only be wiped gently with a damp cloth.

6.2 Disinfection

Disinfect the nursing care bed via wipe-down disinfection. Follow the procedures tested and approved by the Robert Koch Institute (RKI). You can use standard cleansers and disinfectants approved by the RKI. To maintain the durability of plastic components like the motor housing and decorative elements, only mild and gentle products should be used for disinfection. Concentrated acids, aromatic and chlorinated hydrocarbons, higher alcohols, ethers, esters and ketones will corrode the material and therefore should not be used. The list of disinfectant agents and procedures tested and approved by the Robert Koch Institute can be found online at www.rki.de.

We have tested and approved the following disinfectants:

Manufacturer	Product name	Concentration
Ecolab	Incidin Plus	0,5 %-Lösung
Bode Chemie	Bacillol AF	0,5 %-Lösung
Schülke	Terralin Protect	0,5 %-Lösung

6.3 Avoiding hazards

Read the following guidelines for the electrical components of the bed in advance to avoid any hazards related to cleaning and disinfection. Failure to follow these guidelines may lead to a risk of injury and significant damage to electric cords and to the drive system.

- Pull out the mains plug and set it aside to prevent any contact with excessive amounts of water or cleansing agents.
- Check that all connectors are properly seated.
- Check cables and electrical components for damage. If any damage is detected, do not do any cleaning; instead, first have the defects repaired by the operator or by authorised professionals.
- Before returning to normal operation, check the mains plug for any remaining moisture, and wipe or blow it dry if necessary.

- If you suspect that moisture may have got into the electrical components, immediately pull out the mains plug and/or do not plug it back into mains power under any circumstances. Immediately take the bed out of service, mark it accordingly, and inform the operator.

6.4 Machine cleaning



CAUTION

Risk of damage to the product

The suitability of domiflex® 3 beds for machine cleaning is limited to products with the suffix “wash” and the processes and parameters described in this chapter. Any other cleaning processes must be validated by the operator to ensure that the product is not damaged.

Only electrical components with splash protection class IPX6 may remain on the care bed and be washed during machine cleaning.

Remove all electrical components with a lower splash protection class, e.g. any installed dual drives including hand control and power supply unit!

After washing, the electrical components must be checked by trained specialist staff.

Steps required for machine cleaning

The bed must be specially prepared for mechanical cleaning in order to prevent damage. The following steps are required to preserve the service life and functionality of the bed.

- Lower the bed to the lowest position.
- Set up the bed on the supplied transport bracket (see 4.6).
- Check and ensure that the housings for the drive components are undamaged (visual inspection)
- Please note that the side rails can only be cleaned manually. If the coated surface is already damaged, mechanical cleaning will cause moisture to penetrate into the rail, resulting in permanent damage.
- The lifting pole can also be washed if the washing system permits. Otherwise, it can be cleaned manually as well.
- Check that the end panels / lying surfaces with washable electronic components are marked with the following label: 
- Close all sockets of the control unit with the attached blind plugs.
- The jet discharge pressure (directly at the jet’s discharge point) should not exceed 3 bars.

- The surface temperature should not exceed 55°C during the washing and drying process. A washing temperature that is too low should, however, be avoided due to the resulting poor degree of drying.



ATTENTION

Possibility of damage to the product

After each wash cycle of a domiflex® 3 bed, the components must be sufficiently dried. Ensure that all open components are completely dry. Sockets and plugs of the electrical components must not be damp before use.

A comprehensive inspection of the beds must be carried out after each wash cycle. All bed components must be checked for this. Please refer to the inspection list at the end of these instructions. Defective components must be replaced by trained specialist personnel.

Washing parameters

The washability of our beds labeled as “wash” was tested using the following procedure:

- Washing machine of manufacturer Kluge & Fielitz, certified acc. to DIN EN ISO 15883-5
- Dosing of cleaning agents, rinsing agents and disinfectants in accordance with the washing system manufacturer's specifications
- Nozzle outlet pressure (directly at the nozzle outlet) maximum 3 bar
- Maximum surface temperature 55°C

Cleansers and disinfectants

The following cleansers and disinfectants have been successfully tested on the domiflex® 3.

Cleansers	Disinfectant
neodisher MediClean forte	neodisher Dekonta AF
neodisher MediKlar special	Neodisher Septo

Other cleansers and disinfectants can be used to clean the beds; however, they should have similar specifications to the cleansers and disinfectants listed above. They must be approved by the washing system manufacturer.

7 Guidelines and manufacturer declaration

Guidelines and manufacturer declaration

– Electromagnetic emissions

The nursing care bed is intended for use in an environment meeting the criteria listed below. The customer or user of the nursing care bed should verify that the bed is being operated in an appropriate environment.

Emitted interference measurements	Compliance	Electromagnetic environment – Guideline
HF emissions per CISPR 11	as Group 1	The nursing care bed is suitable for use in all facilities excluding those in living areas and those that are directly connected to a public power grid that also supplies buildings used for residential purposes.
HF emissions per CISPR 11	as Class B	
Emission of harmonics as per IEC 61000-3-2	Class B	
Emission of voltage fluctuations/flicker as per IEC 61000-3-3	Compliant	

– Electromagnetic interference immunity

The nursing care bed is intended for use in an electromagnetic environment meeting the criteria listed below. The customer or user of the nursing care bed should verify that the bed is being operated in an appropriate environment.

Interference immunity tests	IEC 60601 test level	Compliance test level	Electromagnetic environment – Guidelines
Electrostatic discharge (ESD) as per IEC 61000-4-2	Contact discharge: ± 8 kV Air discharge: ± 2 kV, ± 4 kV, ± 8 kV, ± 15 kV	Contact discharge: ± 8 kV Air discharge: ± 2 kV, ± 4 kV, ± 8 kV, ± 15 kV	Floors should be made of wood or concrete or be covered with ceramic tiles. If the floor is covered with synthetic material, the relative humidity must be at least 30%.
Electrical fast transients/bursts as per IEC 61000-4-4	± 2 kV for mains power cables ± 1 kV for input and output cables	± 2 kV for mains power cables ± 1 kV for input and output cables	The quality of the power supply should correspond to that of a typical business or hospital environment.
Surge voltages as per IEC 61000-4-5	± 1 kV differential mode voltage	± 1 kV differential mode voltage	The quality of the power supply should correspond to that of a typical business or hospital environment.
Voltage drops, short interruptions and supply voltage fluctuations as per IEC 61000-4-11	0% UT; $\frac{1}{2}$ period; at 0,45,90,135,180,225,270 and 315 degrees; 0% UT; 1 period; 70% UT; 25/30 periods; single-phase at 0 degrees 0% UT, 250/300 periods	0% UT; $\frac{1}{2}$ period; at 0,45,90,135,180,225,270 and 315 degrees; 0% UT; 1 period; 70% UT; 25/30 periods; single-phase at 0 degrees 0% UT, 250/300 periods	The quality of the power supply should correspond to that of a typical business or hospital environment. If the user of the nursing care bed requires continued functionality even in the event of interruptions to the power supply, it is recommended that the nursing care bed be powered from an uninterruptible power supply or a battery.
Magnetic field at supply frequency (50/60 Hz) as per IEC 61000-4-8	30 A/m	30 A/m	Magnetic fields at the mains frequency should correspond to the typical values seen in business or hospital environments.

NOTE: U_T is the mains AC voltage before application of the test level.

– Electromagnetic interference immunity

The nursing care bed is intended for use in an electromagnetic environment meeting the criteria listed below. The customer or user of the nursing care bed should verify that the bed is being operated in an appropriate environment.

Interference immunity tests	IEC 60601 test level	Compliance test level	Electromagnetic environment – Guidelines
Conducted HF disturbances as per IEC 61000-4-6	3 V 150kHz-80MHz	3 V 150kHz-80MHz	
Radiated HF disturbances as per IEC 61000-4-3	6 V in ISM and amateur radio frequency bands	6 V in ISM and amateur radio frequency bands	
Special frequencies as per IEC 61000-4-3, Table 9 were tested as well	10 V/m 80MHz-2700MHz	10 V/m 80MHz-2700MHz	
<p>NOTE 1 At 80 MHz and 800 MHz, the higher frequency range applies.</p> <p>NOTE 2 These guidelines may not be applicable in all cases. Emanation of electromagnetic effects is influenced by absorption and reflection by buildings, objects and people.</p>			
<p>* The field strength of fixed transmitters, e.g. base stations for mobile phones and land mobile radios, amateur radio stations, AM and FM radio broadcasters and TV broadcasters, cannot be theoretically predicted with accuracy. To determine the electromagnetic environment with regard to fixed transmitters, an investigation of the specific site should be considered. If the field strength measured at the site where the nursing care bed is being used exceeds the upper compliance limit, the nursing care bed should be monitored to ensure that it is functioning as intended. If unusual performance characteristics are observed, additional measures may be necessary, e.g. changing the orientation or location of the nursing care bed.</p> <p>^a Above the frequency range from 150 kHz to 80 MHz, the field strength should be less than 3 V/m.</p>			

7.1 EU declaration of conformity

We, Hermann Bock GmbH, declare under our sole responsibility that this medical device complies with the requirements of the Medical Device Regulation (EU) 2017/745.

The current declaration of conformity can be found on our website: www.bock.net.

8 Safe use in a domestic environment

Detection and avoidance of possible unfavourable application conditions

Electrical components of the nursing care bed	
Unfavourable application condition	Possible measures for prevention
Damage to the hand control	Securely fasten the hand control to the bed with the attached hook.
Damage to the hand control cable	Check the course of the hand control cable and route it away from shearing and crushing points
Heat accumulation due to lint or dust	Regular cleaning of the components
Defective electrical cables due to pets and children	Do not leave pets and children unattended in the room
Defective electrical cables due to pests and/or vermin	Have pests/vermin removed by qualified personnel
Defective electrical cables due to crushing and shearing	Fix electrical cables so that they cannot be crushed or sheared off.

Interfering devices and objects	
Unfavourable application condition	Possible measures
Fire hazard due to hot, stationary objects (fireplace, cooker, oven, radiator ...) in the vicinity of the nursing care bed	Select a location for the nursing care bed with a safe distance.
Fire hazard due to hot, movable objects (reading lamp, radiant heater, ...) in the vicinity of the nursing care bed	Keep a safe distance from these objects or replace them, for example with LED lamps.
Collision due to adjustment movement of the nursing care bed	Choose a location for the nursing care bed with a safe distance.
Pinching of hoses for ventilation or positioning of residents	Fix the hoses so that they cannot be pinched.

9 Regular inspections with service



WARNING

Risk of injury

Service and maintenance must not be carried out while the nursing care bed is being used by a person.

Regular inspections help to maintain the highest possible level of safety and are therefore an important safety measure in themselves. Medical devices must be regularly inspected at the intervals specified by the manufacturer and in accordance with generally recognised good engineering practice. In day-to-day practice, the protective measures required for safety reasons are subject to various stresses and requirements, and thus also to the potential signs of associated wear. To reliably minimise risks, it is essential to consistently comply with regular inspection intervals at all times. The manufacturer has no influence over the extent to which the operator of its electric beds complies with the applicable rules. Hermann Bock GmbH makes it easier for you to comply with all necessary safety measures with its time-saving service offerings.

Inspections, assessments and documentation may only be done by or under the supervision of qualified professionals, such as qualified electricians or people with technical training in electrical systems, who are familiar with the applicable guidelines and able to recognise potential impacts and hazards.

Hermann Bock GmbH will provide any necessary descriptions, instructions, or other documents upon request.

If no one on the user's side is qualified for or assigned to perform regular inspections, the Bock service department can take over the regular inspections for a fee, while also confirming and complying with the appropriate inspection intervals.

The nursing care bed must be inspected at least once per year, as well as before and after each new use.

Hermann Bock GmbH offers an inspection checklist to support you in this process. You can copy this checklist or download it at www.bock.net. Completed checklists constitute an audit trail and should be retained in your files.

Note: Any unauthorised technical modification to the product shall immediately void the warranty.

Inspection checklist for Bock nursing care beds

Page 1 of 2

Publication date: 01/09/2021 / Ver. 08

Model number / Year of manufacture:		
Serial/Inventory no.:		
Manufacturer:	Hermann Bock GmbH	



Visual/Functional inspection:

No	Description	Yes	No
General:			
1	Type plate/sticker present on bed and legible?	<input type="checkbox"/>	<input type="checkbox"/>
2	User manual available?	<input type="checkbox"/>	<input type="checkbox"/>
3	Does operator's use comply with the product's intended use?	<input type="checkbox"/>	<input type="checkbox"/>
4	Is the safe working load indicated on the type plate (patient weight + mattress weight + accessory weight) complied with?	<input type="checkbox"/>	<input type="checkbox"/>
5	Are accessories (e.g. lifting pole incl. grip and strap, grab rail, bumper wheels, etc.) safe and free of defects? Are all accessories securely fastened in place and free of any signs of wear? Is the grip on the lifting pole no older than 5 years (usable service life of the grip as per manufacturer guidelines)? Is the correct attachment method used for the lifting pole (welded instead of edged), or has it already been retrofitted?	<input type="checkbox"/>	<input type="checkbox"/>
6	For retrofitted lifting pole sockets, screw tightened to 6-9 NM?	<input type="checkbox"/>	<input type="checkbox"/>
7	Are mechanical fasteners (screws, bolts etc.) complete and free of defects? Screws fully tightened?	<input type="checkbox"/>	<input type="checkbox"/>
8	Can any splinters, cracks or other damage be detected in the wood?	<input type="checkbox"/>	<input type="checkbox"/>
Electrical components:			
9	Are power cables, connecting cords and plugs free of breaks, kinks or pinched areas, abrasions, porous areas and exposed wires?	<input type="checkbox"/>	<input type="checkbox"/>
10	Strain relief device firmly screwed into place and working properly?	<input type="checkbox"/>	<input type="checkbox"/>
11	Safe, correct cable management?	<input type="checkbox"/>	<input type="checkbox"/>
12	Motor and hand control housings free of damage? Has any moisture made its way inside?	<input type="checkbox"/>	<input type="checkbox"/>
13	Is the power supply unit free of damage?	<input type="checkbox"/>	<input type="checkbox"/>
14	Motor's lift tube and clevis free of damage and defects?	<input type="checkbox"/>	<input type="checkbox"/>
15	Hand control (buttons and lock mechanism) free of defects? Limit switch functioning correctly?	<input type="checkbox"/>	<input type="checkbox"/>
16	Block battery/Emergency lowering system: Working correctly and free of defects?	<input type="checkbox"/>	<input type="checkbox"/>
17	<i>For adi.flex bed only:</i> Has the lift tube been sprayed with silicone spray?	<input type="checkbox"/>	<input type="checkbox"/>
Base frame (for scissor beds) / end panels (for beds with end panels actuators):			
18	Is the base frame construction free of defects and cracked welding joints?	<input type="checkbox"/>	<input type="checkbox"/>
19	Are castors and bumper wheels (if present) free of damage?	<input type="checkbox"/>	<input type="checkbox"/>
20	Plastic end caps and mechanical fasteners (screws, bolts etc.) complete and free of defects?	<input type="checkbox"/>	<input type="checkbox"/>
21	Vertical adjustment working correctly and free of defects?	<input type="checkbox"/>	<input type="checkbox"/>
22	Safe braking and locking operation, wheels spinning freely?	<input type="checkbox"/>	<input type="checkbox"/>
Lying surface/mattress base and end panels:			
23	Wooden slats, aluminium/steel slats, support plate and/or springs free of defects? (no cracks or fractures, firmly seated, adequate load pressure, etc.) <i>For dino bed only:</i> Aluminium slats no more than 6 cm apart?	<input type="checkbox"/>	<input type="checkbox"/>
24	Lying surface frame and lifting components free of defects, and no damage to welding joints?	<input type="checkbox"/>	<input type="checkbox"/>

Inspection checklist for Bock nursing care beds

Page 2 of 2

Publication date: 01/09/2021 / Ver. 08

Client:		
Address:		
Location:		

No	Description	Yes	No
25	Plastic end caps and mechanical fasteners (screws, bolts etc.) complete and free of defects?	<input type="checkbox"/>	<input type="checkbox"/>
26	Head and foot end panels firmly seated and free of damage?	<input type="checkbox"/>	<input type="checkbox"/>
27	Back/leg rest adjustment and special functions working correctly and without obstruction?	<input type="checkbox"/>	<input type="checkbox"/>
28	Secure ratchet mechanism of the lower leg rest (if present) in every level, even under load?	<input type="checkbox"/>	<input type="checkbox"/>
29	<i>domiflex® 2 bed only</i> : Do the 6 eccentric clamps provide adequate clamping? The lock nut must be tightened to at least 6 NM.	<input type="checkbox"/>	<input type="checkbox"/>

Side rails:			
30	Side rails in place and free of cracks, breaks or damage?	<input type="checkbox"/>	<input type="checkbox"/>
31	Side rail beams no more than 12 cm apart?	<input type="checkbox"/>	<input type="checkbox"/>
	<i>For dino bed only</i> : Vertical bars no more than 6 cm apart? Distance between side rail system and lying surface no more than 6 cm?		
32	Top of side rail more than 22 cm above mattress surface?	<input type="checkbox"/>	<input type="checkbox"/>
	<i>For dino bed only</i> : Top of side rail more than 60 cm above mattress surface?		
33	<i>For divided side rails only</i> : Distance between end panel and side rails or distance between divided side rails less than 6 cm or greater than 31.8 cm?	<input type="checkbox"/>	<input type="checkbox"/>
34	Side rails slide easily in tracks and lock securely into place?	<input type="checkbox"/>	<input type="checkbox"/>
	<i>For dino bed only</i> : Gates slide easily along aluminium profiles? Gates lock securely into locking mechanism?		
35	Are the side rails/parts adequately fastened or firmly seated?	<input type="checkbox"/>	<input type="checkbox"/>
36	Side rail stress test with no deformation?	<input type="checkbox"/>	<input type="checkbox"/>

Electrical tests:

Insulation resistance - (Only needs to be measured for models built before 2002.)

38	Insulation resistance - measured value greater than 7 MΩ?	<input type="checkbox"/>	<input type="checkbox"/>
----	---	--------------------------	--------------------------

Device leakage current - (This measurement does not have to be carried out for nursing care beds from date of manufacture 2018-05 with drive set from company Limoss or from date of manufacture 2015-07 with a drive set from company Dewert in the first 10 years of the service life if the visual and functional test is passed, provided it is a nursing care bed with a switch-mode power supply (SMPS) from Limoss or Dewert. For these beds, the SMPS converts the mains voltage directly into a safety extra-low voltage no greater than 35 V.)

39	Direct measurement of device leakage current - measured value less than 0.1 mA?	<input type="checkbox"/>	<input type="checkbox"/>
----	---	--------------------------	--------------------------

Evaluation:

40	All values in acceptable range, inspection passed?	<input type="checkbox"/>	<input type="checkbox"/>
----	--	--------------------------	--------------------------

If inspection not passed:

Repair
 Reject

Date / Inspector's name in block letters / Inspector's signature

Next inspection

--	--



Hermann Bock GmbH
Nickelstr. 12
D-33415 Verl

Telephone: +49 (0) 52 46 92 05 - 0
Telefax: +49 (0) 52 46 92 05 - 25
Internet: www.bock.net
E-Mail: info@bock.net



Our SALES PARTNERS

Just like us, our business partners are focused on quality, innovation, and exceptionally high standards that are recognised worldwide. We can rely on our partners as confidently as you rely on us.

Please note that training, replacement parts, repairs, inspections and other forms of service can only be provided by our authorised personnel and sales partners. Otherwise, all warranty claims will be void.

For a list of our current sales partners, see <https://en.bock.net/contact/distribution-partners>.